

LEASE AGREEMENT

TELECOMMUNICATIONS FACILITY/TOWER 222 RIVER ROAD, LEEDS, MA

This Lease Agreement is entered into this 14th day of May, 2000 between the Hampshire Council of Governments (hereinafter referred to as the "COUNCIL") and Sprint Spectrum L.P., a Delaware limited partnership having a mailing address at Crossroads Corporate Center, Suite 800, One International Boulevard, Mahwah, NJ 07495 (hereinafter referred to as the "LESSEE").

The responsible parties to receive any notices under this Lease Agreement are the Board of Councilors for the COUNCIL with an address of 99 Main Street, Northampton, MA 01060 and the Director, Site Development-Northeast Region of the LESSEE with an address of Sprint PCS, Crossroads Corporate Center, Suite 800, One International Boulevard, Mahwah, NJ 07495, with a copy to Sprint Spectrum L.P., 4900 Main Street, Kansas City, MO 64112

1. LEASE OF THE PREMISES:

A. PREMISES: The COUNCIL hereby leases to the LESSEE and the LESSEE hereby leases from the Council building exterior space for attachment of antennas, land consisting of approximately 450 square feet upon which LESSEE will construct its equipment base station and space required for cable runs to connect the base station equipment and antennas, all on the real estate owned by the Council on 222 River Road in Leeds, Massachusetts, being part of the Premises described in a deed dated December 1, 1913, and recorded in the Hampshire County Registry of Deeds in Book 697, Page 161 (the "Council's Property") together with the non-exclusive right of ingress and egress, seven (7) days a week, twenty-four (24) hours a day, on foot or motor vehicle, including trucks, and for the installation and maintenance of utility wires, poles, cables, conduits, and pipes, over, under, or along a 20 foot wide existing right-of-way extending from River Road to the demised Premises. Said demised Premises and right-of-way for access are approximately shown in Exhibit "A" attached hereto and made a part hereof (the "Premises").

B. USE OF THE PREMISES: The Lessee and its sub-tenants, invitees may use the Premises for the purpose of constructing, installing, maintaining, replacing, removing and operating a wireless telecommunications facility for personal communications services on an existing water tower, foundation, antennas, utilities, equipment shelters and pads, fencing, supporting equipment thereto and back-up power sources (including generators and liquid propane storage tanks not greater than 1000 gallons in size) (collectively referred to as the "Facility") in accordance with all approved governmental permits. The LESSEE shall obtain all necessary local, state, and federal permits and shall provide copies of such permits to the COUNCIL prior to occupying the Premises. Local permitting shall be independent from this Lease Agreement and in no way shall granting of this Lease be construed as granting of any local permits. The LESSEE shall not use the Premises for any other purposes without the written consent of the COUNCIL.

C. EASEMENT AND ACCESS: The COUNCIL hereby grants to the LESSEE, the right to temporarily access and use land adjacent to the Premises but part of the COUNCIL'S property, as needed for construction purposes.

The Hampshire Council of Governments also hereby grants to LESSEE the right to survey the Premises, and said survey shall then become Exhibit "B" which shall be attached hereto and made part hereof, and shall control in the event of boundary and access discrepancies between it and Exhibit "A". The cost for such work shall be borne by LESSEE.

D. SITE TESTING: The LESSEE, at its option following full execution of this Agreement, may perform engineering surveys, or any other testing which may be required in order for LESSEE to occupy the Premises.

E. CO-LOCATION, AND MUNICIPAL USE: Any changes in the current tower require Council of Governments' approval in writing, such approval not to be unreasonably withheld, conditioned or delayed. Space may be provided on the Council's Property (but not the Premises) for communication antennas and associated equipment for Hampshire Council of Government emergency services, if requested; provided that

such antennas and equipment shall not (a) result in technical interference problems with LESSEE's then existing equipment or (b) encroach onto the Premises.

F. PROTECTION AGAINST INTERFERENCE: Any equipment installed by the LESSEE on the Premises shall not cause interference to any existing telecommunications radio equipment operated by the COUNCIL on the Council's Property or to existing communications equipment operating in the vicinity of the Facility. Likewise, the COUNCIL will not permit the installation of any future radio equipment on the Council's Property, which would cause interference to the LESSEE'S or sub lessee's equipment or which would encroach onto the Premises.

2. TERM/COMMENCEMENT DATE:

A. This Lease shall be for initial term of five (5) years beginning on the date the lease is signed. The LESSEE shall provide at least ten (10) days written notice to the COUNCIL that work will commence on the Premises.

B. The Lessee shall have the right to extend this Lease beyond the initial term for three (3) successive renewal terms of five (5) years each. This Lease Agreement shall automatically renew for each renewal term unless the LESSEE provides the COUNCIL notice of intention not to renew at least ninety (90) days prior to the expiration of the initial term or any renewal term.

3. RENT:

A. The LESSEE shall pay to the COUNCIL as rent for use of the Premises the sum of One Thousand Five hundred dollars (\$1,500.00)per month . Rent is to be paid in twelve monthly installments due and payable on or before the first day of each month. The initial payment shall be due on or before the Commencement Date of this Lease. Rent for occupancy of partial months shall be prorated. Rental payments shall be payable to Hampshire Care and sent to Hampshire Care 222 River Road, Leeds, MA 01053.

Rent for each renewal term will be the annual rent in effect for the final year of the initial term or prior renewal term, as the case may be, increased by fifteen percent (15%).

B. If LESSEE fails to make payment within fifteen (15) days of the due date, LESSEE shall pay a late charge equal to ten percent (10%) of the monthly lease cost. Nonpayment by the LESSEE within thirty (30) days after receipt of the COUNCIL'S written notice of failure to make payment, may result, at the COUNCIL'S option, in a penalty of ten percent (10%) of the annual rate, or termination of this Lease.

4. COMPLIANCE AUDIT: The LESSEE agrees that the COUNCIL shall, until the expiration of one (1) year after final payment under this Lease have access to and the right to examine any directly pertinent books, documents, papers, and records of LESSEE involving transactions relating to engineering, construction, contracts, and subleasing information affecting the Premises, excluding proprietary or financial information, other than subleasing information, in order to confirm compliance with the terms and conditions of this Lease Agreement. LESSEE agrees that the COUNCIL shall have access during normal working hours and shall be provided adequate and appropriate workspace in order to conduct audits in compliance with the provisions of this section. The COUNCIL shall give the LESSEE ten (10) business days written notice of intended audits and shall conduct such audits at the COUNCIL'S expense.

5. IMPROVEMENTS: All improvements made by the LESSEE on the Premises or any improvements required to make the Premises suitable for the LESSEE'S use shall be at LESSEE'S expense. The LESSEE shall, at its own expense, install any and all utility services required by the LESSEE to operate its equipment. COUNCIL will cooperate with LESSEE in LESSEE's efforts to obtain utilities from any location provided by COUNCIL or the servicing utility, including signing any easement or other instrument reasonably required by the utility company.

6. ASSIGNMENT/SUBLETTING/SALE OF PREMISES:

A. Neither the COUNCIL nor the LESSEE shall assign or transfer this Lease Agreement without the prior written consent of the other party, which consent will not be unreasonably withheld or delayed. Notwithstanding the foregoing, the LESSEE, may assign the Leased Premises or any portion thereof without the COUNCIL'S prior consent, to any entity which controls, is controlled by, is under common control with the LESSEE, or is merged or consolidated with LESSEE, or to any entity which acquires all or a substantial portion of the LESSEE'S assets provided that notification is provided to the COUNCIL. Any such assignment shall not relieve the LESSEE of its obligations under this Lease unless the assignee shall assume and become bound to perform all of the obligations of the LESSEE under this Lease. The COUNCIL agrees that the LESSEE may sublet or otherwise grant use rights to all or any portion of the Facility for the express purpose of leasing space for the installation of an antenna and associated equipment to separate wireless communication carriers.

B. In the event the LESSEE shall become bankrupt or insolvent, or should a trustee or receiver be appointed to administer the LESSEE'S business or affairs, neither this Lease nor any interest herein shall become an asset of such trustee or receiver, and in the event of the appointment of such trustee or receiver, this Lease shall immediately terminate.

C. The COUNCIL may sell the Premises provided it is sold subject to this Lease Agreement and further provided, however, that the LESSEE shall have no obligation to provide free space to the purchaser and any instrument effectuating said conveyance shall specifically refer to this Lease Agreement as well as the Memorandum of Lease on record at the Hampshire County Registry of Deeds.

7. TAXES: The Council pays the City of Northampton payments in lieu of property taxes. Any assessed value attributable to the LESSEE'S equipment or improvements as would have been due on like taxable property shall be payable to the COUNCIL by the LESSEE. The COUNCIL shall provide written evidence of such assessment. If the property is sold to a private entity, the LESSEE agrees to pay the value in real property taxes which may be assessed upon that portion of the property, of which the Premises is a part, as a direct result of LESSEE'S Facility. Personal property taxes assessed upon LESSEE'S Facility pursuant to Chapter 59 of the Massachusetts General Laws shall be payable by the LESSEE.

8. COMPLIANCE WITH LAWS: The LESSEE shall comply with all applicable local, state, and federal laws and regulations for the duration of this lease including but not limited to FCC power levels, frequencies, and electromagnetic radiation emissions and Northampton Zoning Bylaw Special Permit conditions. It is understood by both parties, that the LESSEE'S obligations hereunder are contingent upon its obtaining all necessary permits and approvals which may be required to operate the Facility. In the event that any such applications should be rejected, or any such permits or approvals are terminated by a government authority, and the LESSEE in its sole discretion determines that it will be unable to use the Premises for its intended purposes, the LESSEE shall have the right to terminate this Lease. LESSEE shall comply with all federal, state, and local laws, regulations and by-laws governing the use, storage, and disposal of oil, gasoline, and hazardous materials.

9. REPAIRS AND MAINTENANCE: LESSEE shall maintain the Premises, as per the City of Northampton's zoning By-law, in good order and condition at all times during the term of this Lease including not limited to maintenance of any landscaping, screening, or other maintenance required under any permits; maintenance of the access road from Hampshire Care to the Facility; and maintenance of LESSEE'S Facility including fencing in accordance with reasonable business practices. The COUNCIL reserves the right to specify reasonable screening, landscaping, paint colors, and signs based on the proposed design.

10. LIABILITY AND INSURANCE:

A. LESSEE covenants and agrees to save harmless and indemnify COUNCIL from any liability for injury, loss, accident or damage to any person or property and from any claims, actions, proceedings and expenses and costs in connection therewith (including, without limitation, reasonable counsel fees), and (i) arising from the negligence or intentional misconduct of LESSEE and not due to the negligence or willful

misconduct of COUNCIL, or (ii) resulting from the failure of LESSEE to perform and discharge its covenants and obligations under this LEASE, or (iii) resulting from any act or omissions of LESSEE which involve the disposal or storage of any debris, pollutants, contaminated or hazardous materials or wastes resulting from LESSEE'S operation of its business or the use of the premises. In no event shall the COUNCIL be liable for any damage to any person or to any property of any person, including, but not limited to, the LESSEE, its agents, servants or employees or business invitees arising out of the LESSEE'S use of the premises, unless caused by COUNCIL'S negligence or intentional misconduct.

B. The awarded vendor must supply a Certificate of Insurance listing liability and worker's compensation coverage, through a company licensed to do business in the State of Massachusetts. The contractor shall at all times during the contract maintain in full force and effect Worker's Compensation, Employer's Liability, Public Liability and Property Damage Insurance, including contractual liability coverage. All insurance shall be by insurers and for policy limits acceptable to the Council and before commencement of work hereunder the contractor agrees to furnish the Council certificates of insurance or other evidence satisfactory to the Council to the effect that such insurance has been procured and is in force. The certificates shall contain the following express obligation:

"This is to certify that the policies of insurance described herein have been issued to the insured for whom this certificate is executed and are in force at this time. In the event of cancellation or material change in a policy affecting the certificate holder, thirty (30) days prior written notice will be given the certificate holder."

For the purpose of the contract, the contractor shall carry the following types of insurance in at least the limits specified below:

COVERAGES	LIMITS OF LIABILITY
Worker's Compensation	Statutory
Employer's Liability	\$500,000.00
Bodily Injury Liability Except Automobile	\$500,000.00 each occurrence \$1,000,000.00 aggregate
Property Damage Liability Except Automobile	\$500,000.00 each occurrence \$1,000,000.00 aggregate
Automobile Bodily Injury Liability	\$500,000.00 each person \$1,000,000.00 each occurrence
Automobile Property Damage Liability	\$500,000.00 each occurrence
Excess Umbrella Liability	\$1,000,000.00 each occurrence

The Council shall be named as an additional insured under the liability insurance. The general liability insurance policy should contain a broad form general liability endorsement.

11. HAZARDOUS SUBSTANCES: The COUNCIL represents that it has no knowledge of use, generation, storage or disposal of any hazardous substance on, under or about the Council's Property in violation of any law or regulation. The LESSEE agrees not to use, store, generate, or dispose of any hazardous substance on the Premises and upon the Council's property in violation of any law or regulation. The LESSEE shall keep the Premises free from all refuse generated by LESSEE and shall, in a reasonably prompt manner, remove all garbage and refuse of any kind generated by LESSEE from the Premises.

12. NOTICES AND OTHER COMMUNICATIONS: Any notices or communications that are required herein, or

which either the COUNCIL or the LESSEE may desire to serve upon the other, shall be in writing and shall be deemed served when personally delivered and signed for, or when mailed or delivered by any means which provides for a return receipt, addressed to the responsible parties named at the addresses first written above. Each party may designate a change of notice address by giving written notice to the other party.

13. TERMINATION:

A. LESSEE may terminate this Lease upon giving thirty (30) days written notice to the COUNCIL if: (1) LESSEE does not obtain or loses any governmental permits or approvals or any third party easements necessary to construct, install or operate its Facility and is thereby unable to use the Premises for its intended purpose; (2) COUNCIL fails to have proper ownership of the Premises or authority to enter into this Lease Agreement; (3) if the title is otherwise subject to easements or restrictions which will materially interfere with LESSEE'S use of the premises for its intended purposes or will result in an increase in the cost to construct the tower; or (4) the site investigation described in Section 1.D hereof are deemed unacceptable to LESSEE; or (5) if LESSEE can show with reasonable justification that it will be unable to use the Premises for its intended purpose.

B. COUNCIL may terminate this Lease upon failure by LESSEE to pay any rent required hereunder when due, if such failure shall continue for more than thirty (30) days after receipt by LESSEE of written notice of failure to make timely payment.

C. Either party may pursue any remedies available to it under applicable law, including termination of this Lease, if the other party fails to comply with any term, condition, or covenant of this lease and does not cure such failure within thirty (30) days after written notice thereof or in the event of a cure which requires in excess of thirty (30) days to complete, if the defaulting party has not commenced such cure within thirty (30) days of such notice and is not diligently prosecuting said cure to completion.

D. At the conclusion of the LESSEE'S tenancy, LESSEE shall remove all its personal property and equipment located on the Premises and shall, at the request of the COUNCIL, remove any buildings and other structures erected by LESSEES at the Premises, including any connections to other utilities and LESSEE shall then restore the Premises to their condition at the commencement of the lease term, reasonable wear and tear and casualty loss excepted. To the extent that the Council, at the conclusion of LESSEE'S tenancy, does not require the removal of any building or other structures, or utility connections, and to the extent that LESSEE chooses and intends to leave such buildings, structures or utility connections on the Premises, LESSEE agrees to execute such documents necessary to effect the transfer to the Council of such buildings, connection and structures.

14. MISCELLANEOUS:

A. COUNCIL covenants that COUNCIL has sufficient title to the Premises, that the Premises are free from all encumbrances except those of record, and that it has full authority to enter into this Lease Agreement. COUNCIL further covenants that LESSEE, on paying the rents and performing the covenants, terms, and conditions herein, shall peaceably and quietly have, hold and enjoy that portion of the Premises governed by this Lease. COUNCIL shall not have unsupervised access to the Premises or the facility.

B. This Agreement, including any attachments, constitutes the entire Agreement between the parties and supersedes all prior written and verbal agreements, representations, promises or understandings between the parties; any amendments or waivers to this Agreement shall be in writing and executed by both parties; this lease shall extend to and bind the heirs, personal representatives, administrators, successors and assigns of the parties; this Agreement and the performance thereof shall be governed, interpreted, construed, and regulated by the laws of the Commonwealth of Massachusetts; if any provision of this Lease is held invalid or unenforceable, the remaining provisions shall remain binding and enforceable upon the parties to the fullest extent permitted by law; and the prevailing party in any action or proceeding brought to enforce this Lease shall be entitled to recover its reasonable attorney's fees, costs, and expenses in connection with such action or proceeding from the other party.

C. Title to LESSEE'S equipment installed at and affixed to the Premises shall be and shall remain the

property of the LESSEE. The LESSEE may, at any time, remove its equipment, fixtures, and personal property from the Premises without consent of the COUNCIL provided all conditions for removal of such equipment specified under this Agreement are met.

D. COUNCIL agrees that LESSEE or any other authorized sub-lessee or user has or may enter into financing arrangements with third party financing entities for the financing of the Facility and/or their Leasehold or other use rights in connection therewith. COUNCIL disclaims any interest, now or in the future, in the Facility, as fixtures or otherwise; agrees that the Facility and the Leasehold or other use interest of LESSEE or its authorized sub-lessee's or users shall be exempt from execution, foreclosure, sale, levy, attachment, or distress for any rent due or to become due; and agrees to provide any such lender with a statement regarding the above facts and any other information reasonably requested, such as lack of a default hereunder, within a timely manner.

E. WAIVER. The failure on the part of any party of this LEASE to complain of any action or non-action on the part of the other party, no matter how long the same may continue, shall never be deemed to be a waiver by such party of any of its rights hereunder. Further, it is covenanted and agreed that no waiver at any time of any of the provisions hereof by either party shall be construed as a waiver of any of the other provisions hereunder and that a waiver at any time of any of the provisions hereof shall not be construed as a waiver at any subsequent time of the same provisions. The consent or approval by the COUNCIL to or of any action by the LESSEE requiring the COUNCIL'S consent or approval shall not be deemed to waive or render unnecessary the COUNCIL'S consent or approval to or of any subsequent similar act by the LESSEE.

F. LESSEE has completed and submitted to the Council prior to the execution of this Lease Agreement a copy of a Disclosure of Beneficial Interest in Real Property Transaction from which shall become part of this Agreement as Exhibit C.

FOR THE COUNCIL:

Vice - Debra Stewart (Signature) May 1, 2000 Date
Chairperson, Hampshire Council

FOR THE LESSEE:

_____ (Signature) _____ Date

APPROVED AS TO FORM:

_____ Date

Exhibit A

Plans of Premises

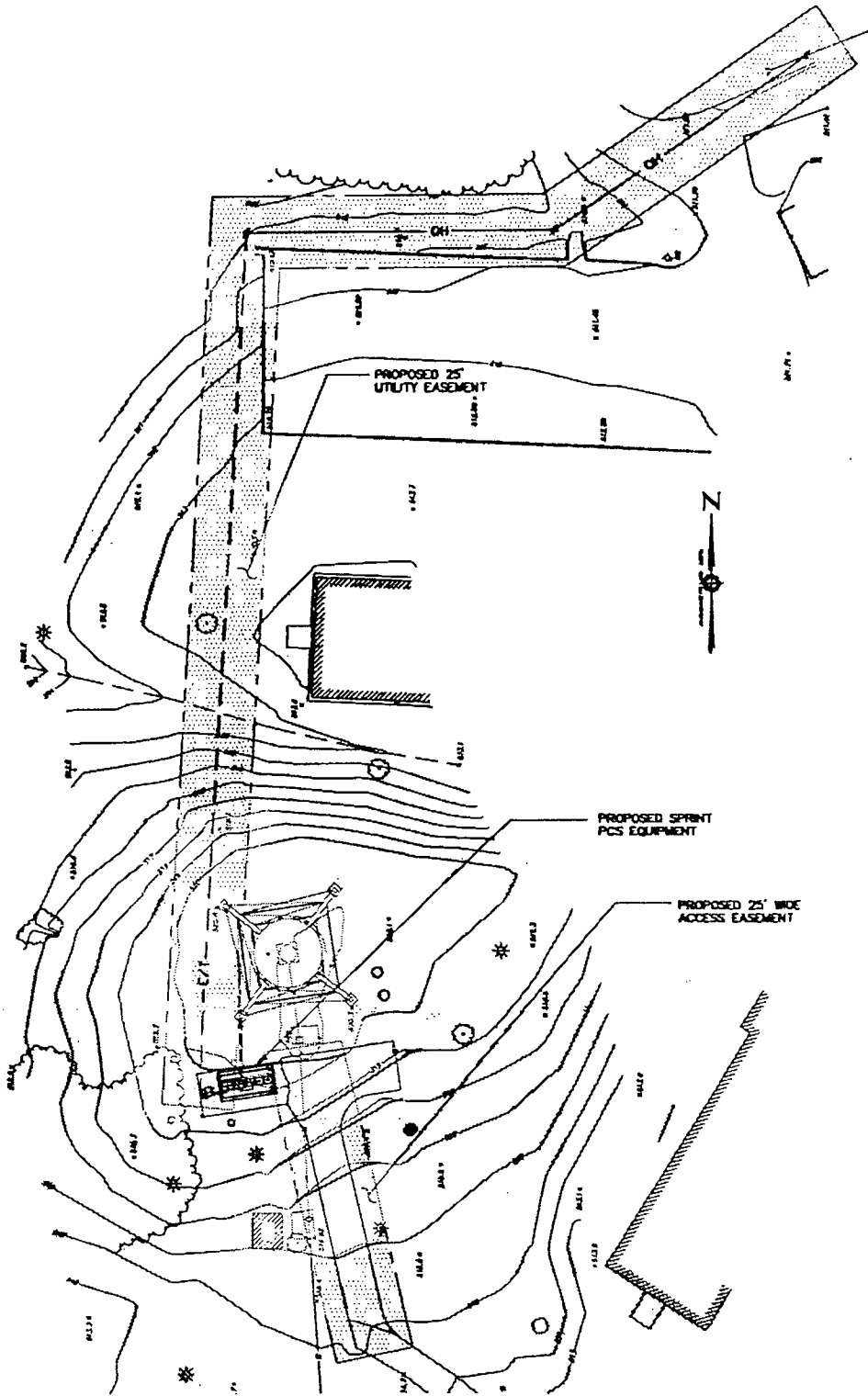

INITIALS
 JS

1 SITE PLAN
 SK-1 SCALE: 1"=60'-0"

FINAL UTILITY EASEMENT TO BE COORDINATED WITH UTILITY COMPANY

SITE ID NO: BS33XC084
 Designed by:
 Drawn by: JM
 Checked by: AA
 Approved by: DJR

MRS Greiner Woodward Clyde
A-E-S
 500 ENTERPRISE DRIVE
 ROCKY HILL, CONNECTICUT
 1-(860)-629-8882

SPRINT PCS
9 BARNES INDUSTRIAL ROAD
WALLINGFORD, CT
HOBART II
 222 RIVER ROAD
 NORTHAMPTON, MASS. 01053

REV.	DATE	DESCRIPTION

Scale: AS SHOWN Date: 11-18-99
 Job No. F301772.29 File No. []

Dep. No.
SK-1
 Dep. 1 of 1

PROPOSED SPRINT
PCS ANTENNAS
(TYP. OF 8)

ANTENNA C

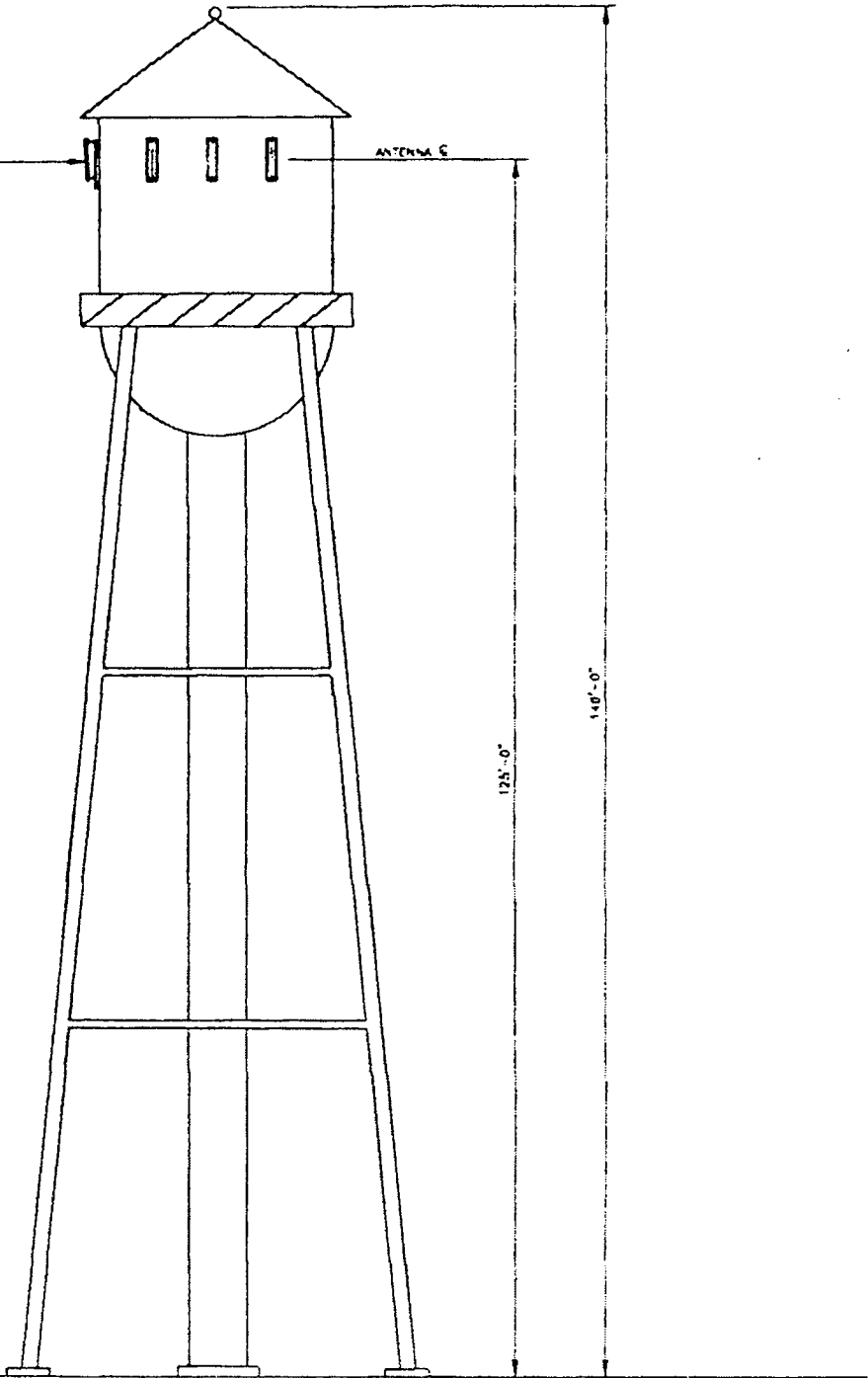

INITIALS
ES

APPROXIMATE GRADE

1 WATER TOWER ELEVATION
L-2 SCALENTS

SITE NO:
ES13MCD84

Designed by:

Drawn by: JD

Checked by: AA

Approved by: DJR

SES Greiner Woodmont Cycle
A-E-S
500 ENTERPRISE DRIVE
ROCKY HILL, CONNECTICUT
1-(800)-629-8882

SPRINT PCS
9 BARNES INDUSTRIAL ROAD
WALLINGFORD, CT

HOBART II
NORTHAMPTON MASS.

REV.	DATE	DESCRIPTION

Revised AS SHOWN Date: 04/20/89

Job No. F30177228 (File No. L-2)

Dep. No.
L-2
Dwg. 2 of 2

Exhibit B

Survey-if ordered by LESSEE